

# Four versus Six Courses of a Dose-Escalated Cyclophosphamide, Doxorubicin, Vincristine, and Prednisone (CHOP) Regimen plus Etoposide (MegaCHOEP) and Autologous Stem Cell Transplantation

## *Early Dose Intensity Is Crucial in Treating Younger Patients with Poor Prognosis Aggressive Lymphoma*

Nobert Schmitz, M.D., Ph.D.<sup>1</sup>

Marita Kloess<sup>2</sup>

Marcel Reiser, M.D.<sup>3</sup>

Wolfgang E. Berdel, M.D., Ph.D.<sup>4</sup>

Bernd Metzner, M.D.<sup>5</sup>

Bernd Dorken, M.D., Ph.D.<sup>6</sup>

Michael Kneba, M.D., Ph.D.<sup>7</sup>

Lorenz Trumper, M.D., Ph.D.<sup>8</sup>

Markus Loeffler, M.D., Ph.D.<sup>2</sup>

Michael Pfreundschuh, M.D., Ph.D.<sup>9</sup>

Bertram Glass, M.D., Ph.D.<sup>8</sup>

for the German High-Grade Non Hodgkin's Lymphoma Study Group (DSHNHL)

**BACKGROUND.** Patients with aggressive lymphoma and high-risk features at the time of diagnosis are reported to have a poor prognosis with standard therapy. Attempts to improve the results achieved with the combination of cyclophosphamide, doxorubicin, vincristine, and prednisone (CHOP) using second-generation or third-generation chemotherapy have failed. In the current study, the authors increased the doses and dose intensity of drugs used for the conventional first-line therapy of aggressive lymphoma and designed a Phase II randomized trial that compared four and six courses of dose-escalated CHOP plus etoposide (mega-CHOEP) supported by the transplantation of peripheral blood stem cells.

**METHODS.** Eighty-four patients age < 60 years with aggressive lymphoma and elevated lactate dehydrogenase (LDH) levels were randomized to receive either 4 (Arm A) or 6 (Arm B) courses of cyclophosphamide, doxorubicin, vincristine, etoposide, and prednisone (megaCHOEP). The last three treatment courses were supported by autologous peripheral blood stem cell transplantation. Although the

<sup>1</sup> Department of Hematology, AK St. Georg, Hamburg, Germany.

<sup>2</sup> Institute of Medical Informatics, Statistics, and Epidemiology, University of Leipzig, Leipzig, Germany.

<sup>3</sup> Department of Internal Medicine I, University of Cologne, Cologne, Germany.

<sup>4</sup> Department of Medicine, Division of Hematology and Oncology, University of Munster, Munster, Germany.

<sup>5</sup> Department of Hematology and Oncology, Stadtische Kliniken Oldenburg, Oldenburg, Germany.

<sup>6</sup> Department of Hematology and Oncology, University Medicine Berlin, Charite, Berlin, Germany.

<sup>7</sup> Department of Internal Medicine II, University of Kiel, Kiel, Germany.

<sup>8</sup> Department of Hematology and Oncology, University Hospital Gottingen, Gottingen, Germany.

<sup>9</sup> Department of Internal Medicine I, Saarland University Medical School, Homburg/Saar, Germany.

Supported by an unrestricted grant from AMGEN GmbH, Munich, Germany.

The authors would like to thank K. Johanns and S. Wolf for help with the article.

The following institutions are members of the German High-Grade Non Hodgkin's Lymphoma Study Group (DSHNHL) and recruited patients to this study: II. Med. Universitätsklinik, Kiel (M. Kneba); Med. Universitätsklinik, Ulm (H. Doehner); Universitätsklinik, Köln (V. Diehl); Universitätsklinik, Munster (W. E. Berdel); Med. Universität, Lubeck (T. Wagner); Universitätsklinik, Essen (U. Dueshens); Universitätsklinik, Eppendorf, Hamburg (D. K. Hossfeld); Städtisches Klinikum, Karlsruhe (Th. Fischer); Universitätsklinik, Göttingen (L. Trumper); Universitätsklinik, Heidelberg (A. D. Ho); Dr.-Horst-Schmidt Kliniken, Wiesbaden (N. Frickhofen); Bürgerhospital, Stuttgart (H. G.

Mergenthaler); St. Josefs/St. Marien Hospital, Hagen (H. Eimermacher); Universitätsklinik des Saarlandes, Homburg (M. Pfreundschuh); Universitätsklinik Charite, Berlin (B. Dorken); Carl-Thiem-Klinikum, Cottbus (H. Steinhauer); Klinikum Ernst von Bergmann, Potsdam (R. Pasold); Universitätsklinik, Rostock (M. Freund); Stadt. Klinikum, Oldenburg (B. Metzner); Klinikum, Ludwigshafen (H. Brass); Universitätsklinik, Halle (H. J. Schmoll); Universitätsklinik, Bonn (I. Schmidt-Wolf); Franziskus-Hospital, Bielefeld (A. Zumsprekel); and Städtische Klinik, Dessau (A. Florschütz).

Address for reprints: Nobert Schmitz, M.D., Ph.D., Department of Hematology, AK St. Georg, Lohmühlenstrasse 5, D-20099 Hamburg, Germany; Fax: (011) 49 40 181885 4226; E-mail: norbert.schmitz@ak-stgeorg.lbk-hh.de

Received May 31, 2005; revision received June 29, 2005; accepted July 28, 2005.

total doses of cyclophosphamide and etoposide were comparable, the dose intensity during the first 3 treatment courses was planned to be 2.8-fold and 2.0-fold higher, respectively, for patients in Arm A.

**RESULTS.** Thirty-seven patients in Arm A (90.2%) but only 18 patients in Arm B (69.2%) were able to complete therapy ( $P = 0.048$ ). The complete response rate was 65.8% in Arm A and 50.0% in Arm B; the disease recurrence rates were 18.5% versus 61.5% ( $P = 0.011$ ). Freedom from treatment failure at 2 years was 52.5% (95% confidence interval [95% CI], 36.9–68.2%) in Arm A and 23.1% (95% CI, 6.9–39.3%) in Arm B ( $P = 0.02$ ). The overall survival rate was 70% (95% CI, 54.9–85.0%) in Arm A and 46.2% (95% CI, 27.0–65.3%) in Arm B ( $P = 0.037$ ).

**CONCLUSIONS.** The results of the current study demonstrate that dose intensity, in particular early dose intensity, significantly influences disease control with high-dose therapy (HDT) and autologous stem cell transplantation. These results also may explain the failure of HDT with low early dose intensity to improve the results obtained with conventional chemotherapy. *Cancer* 2006;106:136–45.

© 2005 American Cancer Society.

**KEYWORDS:** lymphoma; CHOP (cyclophosphamide, doxorubicin, vincristine, and prednisone), megaCHOEP (cyclophosphamide, doxorubicin, vincristine, etoposide, and prednisone), autologous stem cell transplantation, dose intensity.

**P**atients with aggressive lymphoma and high-risk features at the time of diagnosis have a poor prognosis with standard therapy. According to the International Prognostic Index (IPI), only 26% of patients belonging to the high-risk and 43% belonging to the high intermediate-risk group survive 5 years after diagnosis.<sup>1</sup> Attempts to improve the results achieved with cyclophosphamide, doxorubicin, vincristine, and prednisone (CHOP) using second-generation or third-generation chemotherapy have failed.<sup>2</sup> In younger patients, the role of high-dose chemotherapy (HDT) followed by autologous hematopoietic stem cell transplantation (ASCT) as part of first-line therapy has been investigated.<sup>3–9</sup> Unfortunately, the majority of prospective trials failed to demonstrate a benefit of HDT/ASCT. We theorized that two major problems contributed to the inconclusive results: 1) up to 40% of patients randomized to HDT/ASCT did not receive it, mostly because of early disease progression; and 2) in many instances, the cumulative doses and dose intensities of HDT programs were not higher but occasionally were lower than those of conventional treatment. We chose to increase the doses and dose intensity of the drugs used for the conventional first-line therapy of aggressive lymphoma and designed a Phase II randomized trial that compared treatment with four courses with treatment with six courses of dose-escalated CHOP plus etoposide (megaCHOEP) supported by peripheral blood stem cell (PBSC) transplantation. Although the total doses of cyclophosphamide and etoposide given were identical, patients randomized to the four-course megaCHOEP program were to re-

ceive significantly higher dose intensities, in particular during the first weeks of therapy.

## MATERIALS AND METHODS

### Study Design and Eligibility Criteria

The current study was a prospective, randomized, Phase II, multicenter trial designed to evaluate the feasibility, safety, and efficacy of repeated courses of megaCHOEP facilitated by PBSC transplantation. The study protocol was approved by local ethics committees and informed consent was obtained from patients. Between September 1999 and May 2001, 84 patients were enrolled. Eligible patients were required to have a primary diagnosis of aggressive lymphoma according to the Revised European–American Lymphoma (REAL) classification, translated into the World Health Organization (WHO) classification and confirmed by an expert hematopathologist; have Stage II to Stage IV disease; be ages 18–60 years; and have a lactate dehydrogenase (LDH) level above normal. Patients with lymphoblastic or Burkitt lymphoma, central nervous system (CNS) involvement, bone marrow infiltration > 25%, known positivity for the human immunodeficiency virus, or major organ dysfunction were excluded from the study.

### Staging

Patients were staged according to the Ann Arbor criteria. Individual histories, physical examinations, and blood tests were taken from all patients. We also required a bone marrow biopsy as well as thoracic and abdominal computed tomography scans; further imaging procedures were performed as needed.

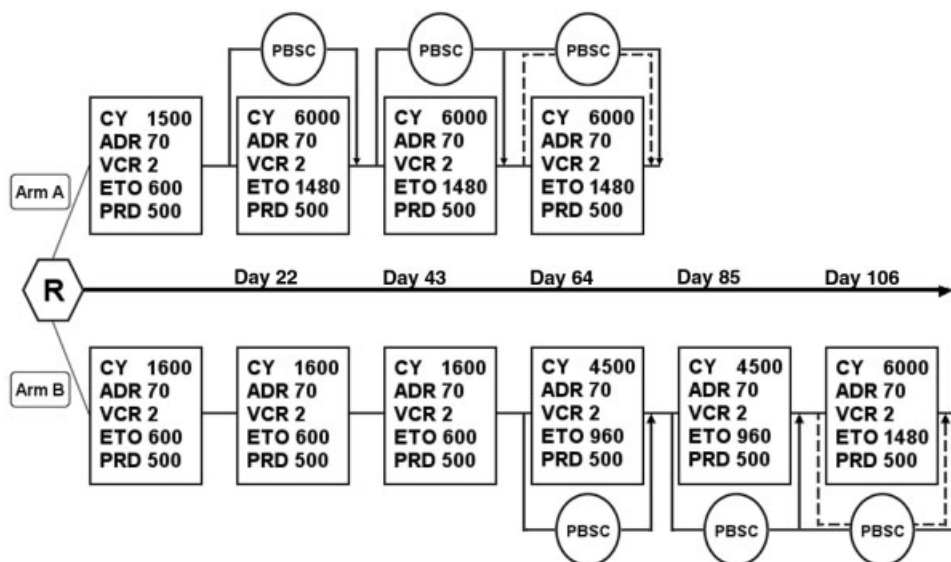

**FIGURE 1.** Study design. All doses are shown as total doses per cycle in  $\text{mg}/\text{m}^2$  with the exception of vincristine (VCR) and prednisone (PRD), which are shown in mg. CY: cyclophosphamide; ADR: doxorubicin; ETO: etoposide; PBSC: peripheral blood stem cell transplantation.

### Chemotherapy

The megaCHOEP protocol was comprised of either four (Arm A) or six courses (Arm B) of cyclophosphamide, doxorubicin, vincristine, etoposide, and prednisone (Fig. 1). In Arm A, the first course of megaCHOEP was comprised of cyclophosphamide at a dose of  $750 \text{ mg}/\text{m}^2$  administered on Days 1 and 2, doxorubicin at a dose of  $35 \text{ mg}/\text{m}^2$  administered on Days 1 and 2, vincristine at a dose of 2 mg administered on Day 1, etoposide at a dose of  $100 \text{ mg}/\text{m}^2$  administered every 12 hours on Days 1–3, and prednisone at a dose of 100 mg administered on Days 1–5. The 2nd, 3rd, and 4th course of therapy were identical: cyclophosphamide at a dose of  $3000 \text{ mg}/\text{m}^2$  on Days 1 and 2, doxorubicin at a dose of  $35 \text{ mg}/\text{m}^2$  on Days 1 and 2, vincristine at a dose of 2 mg on Day 1, etoposide at a dose of  $185 \text{ mg}/\text{m}^2$  administered every 12 hours on Days 1–4, and prednisone at a dose of 100 mg administered on Days 1–5. Patients randomized to Arm B received moderately increased doses of cytotoxic agents during treatment Courses 1–3: cyclophosphamide at a dose of  $800 \text{ mg}/\text{m}^2$  on Days 1 and 2, doxorubicin at a dose of  $35 \text{ mg}/\text{m}^2$  on Days 1 and 2, vincristine at a dose of 2 mg on Day 1, etoposide at a dose of  $100 \text{ mg}/\text{m}^2$  every 12 hours on Days 1–3, and prednisone at a dose of 100 mg on Days 1–5. Doses of cyclophosphamide ( $2250 \text{ mg}/\text{m}^2$  on Days 1 and 2) and etoposide ( $160 \text{ mg}/\text{m}^2$  every 12 hrs on Days 1–3) were escalated in Courses 4–6; the doses of doxorubicin, vincristine, and prednisone remained unchanged. For both treatment arms, the next course of chemotherapy was to begin on Day 21 if hematologic recovery had occurred and nonhematologic toxicities from the previous course had resolved.

### PBSC Collection and Transplantation

Patients randomized to Arm A received filgrastim (at a dose of  $5 \mu\text{g}/\text{kg}$  twice daily) from Day 6 after the first course of therapy until the last time leukapheresis was performed. Greater than  $2 \times 10^6$  CD34-positive cells/kg were harvested, cryopreserved, and reinfused after treatment Course 2. After Course 2 and, (if fewer than  $4 \times 10^6$  CD34-positive cells/kg body weight had been harvested,) also after Course 3, PBSC were collected to support hematopoietic recovery after treatment Courses 3 and 4, respectively. Patients randomized to Arm B underwent treatment with filgrastim and the collection of PBSC after treatment Course 3. Further collections were planned after Course 4 and, if necessary, after Course 5. Transplantation of collection products was planned after Courses 4, 5, and 6.

### Supportive Care

Prophylaxis of pneumocystis carinii pneumonia with cotrimoxazole was mandatory; in patients whose serology was positive for the herpes simplex virus, the prophylactic administration of acyclovir was recommended. Other supportive care was given as per local practice.

### Assessment of Hematologic and Extramedullary Toxicities

Organ toxicities were evaluated according to the criteria of Bearman et al.<sup>10</sup>; infections were classified using WHO criteria. Patients were to receive the next course of megaCHOEP if they had reached a platelet count  $> 80/\text{nL}$ , had cleared active infections, and had organ toxicities of Grade 0; liver toxicity could be either Grade 0 or 1.

**TABLE 1**  
**Total Dose, Early Total Dose, Dose Intensity, and Early Dose Intensity of MegaCHOEP Treatment Arms A and B**

		Cyclophosphamide (mg/m <sup>2</sup> )		Doxorubicin (mg/m <sup>2</sup> )		Vincristine (mg)		Etoposide (mg/m <sup>2</sup> )		Prednisone (mg)	
		Arm A	Arm B	Arm A	Arm B	Arm A	Arm B	Arm A	Arm B	Arm A	Arm B
Total dose	Planned dose	19,500	19,800	280	420	8	12	5040	5200	2000	3000
	Received dose (median % of planned)	99	95	100	94	100	92	98	89	100	100
Early total dose	Planned dose (Days 1-63)	13,500	4800	210	210	6	6	3560	1800	1500	1500
	Received dose (median % of planned)	100	100	100	100	100	100	98	96	100	100
Early total dose/ total dose (%) (received doses are given)		70	25	75	53	75	55	71	37	75	50
Dose intensity	Planned dose/week	1625	1100	23.3	23.3	0.67	0.67	420	289	167	167
	Received dose intensity (median % of planned)	79	79	82	84	78	82	76	79	84	88
Early dose intensity	Planned dose/week (Days 1-63)	1500	533	23.3	23.3	0.67	0.67	396	200	167	167
	Received dose intensity (median % of planned)	75	87	79	87	73	90	74	85	80	90

MegaCHOEP: dose-escalated cyclophosphamide, doxorubicin, vincristine, and prednisone plus etoposide.

### Response Evaluation and Follow-Up

Response was assessed 3 months after the cessation of therapy. Patients in whom all pathologic lesions had disappeared and in whom laboratory abnormalities related to lymphoma had normalized for at least 2 months were scored as achieving a complete response (CR). Patients with lesions representing residual masses after therapy but with no indication of active disease were classified as having an unconfirmed CR (CRu). A partial response (PR) was defined as a  $\geq 50\%$  regression at all tumor sites. All other patients were deemed treatment failures. Follow-up visits were scheduled every 3 months for the first 2 years and every 6 months thereafter.

### Total Dose, Dose Intensity, and Duration of Therapy

The total doses of drugs to be administered in Arms A and B of the study are given in Table 1. Dose intensities of doxorubicin, vincristine, and prednisone were calculated to be identical in both arms. The planned dose intensity of cyclophosphamide was 1625 mg/m<sup>2</sup>/week in Arm A and 1100 mg/m<sup>2</sup>/week in Arm B; the dose intensity of etoposide was 420 mg/m<sup>2</sup>/week in Arm A and 289 mg/m<sup>2</sup>/week in Arm B.<sup>11</sup> The duration of therapy was calculated as the time interval between the first day of the first course and Day 21 after the last course of chemotherapy.

### Statistical Analyses

The primary endpoint of the study was the feasibility of the megaCHOEP program as measured by the percentage of patients able to receive all therapy. Sixty patients stratified by gender and Eastern Cooperative Oncology Group (ECOG) performance status (< 2 vs.  $\geq 2$ ) were planned to be enrolled; 1:1 randomization was performed using the minimization method.<sup>12</sup> Case report forms were solicited by the statistical study center after the completion of every single course of therapy. When the Steering Committee of the DSHNHL was informed that disease progression frequently had occurred in patients treated on Arm B, the accrual of additional patients was stopped and patient enrollment continued on Arm A only. By the time the analysis of early treatment failures was complete, 26 patients had been treated on Arm B and 41 patients had received treatment according to Arm A. To describe the number of CD34-positive cells and hematologic recovery times, we used boxplots with the upper and lower limits describing 25% and 75% percentiles, respectively. Dose intensities, both planned and received, were calculated according to an algorithm proposed by Hryniuk and Goodyear.<sup>11</sup> The median total doses, dose intensities, and early dose intensities (Cycles 1-3) were calculated for every patient. Efficacy was measured by calculating the CR

rate, the time to disease progression or recurrence, the time to treatment failure, and overall survival. Death due to any cause as well as disease progression or recurrence was defined as treatment failure. Time to disease progression or recurrence, freedom from treatment failure, and overall survival were measured from the time of the initiation of therapy to the respective event. Survival data were estimated according to the method of Kaplan and Meier. The estimators at 2 years are given with the 95% confidence intervals (95% CI). Differences in patient characteristics and toxicities were tested for significance using the chi-square test and, if required, by the Fisher exact test. Differences in the numbers of CD34-positive cells collected or infused were tested with the Mann-Whitney *U* test. Univariate analysis of treatment effects was performed using the log-rank test. Multivariate analysis was performed with the Cox proportional hazards model. All tests for significance were at the 5% significance level and were not adjusted for multiple comparisons. All eligible patients were included in the analysis.

## RESULTS

### Patients

Seventeen patients enrolled in the current study were not eligible; 4 patients had a diagnosis other than aggressive lymphoma; 4 patients had a history of indolent non-Hodgkin lymphoma (NHL); 2 patients had Burkitt lymphoma; 2 patients withdrew their consent; and 1 patient each had bone marrow involvement of > 25%, a LDH level < the upper limit of normal, hepatitis C infection, age < 18 years, or poor documentation. Forty-one eligible patients were treated on Arm A and 26 patients were treated on Arm B. Thirty-nine patients on Arm A had their diagnosis confirmed by central review. Twenty-three patients had diffuse large B-cell lymphoma (56%), 6 patients had mediastinal B-cell lymphoma, 6 patients had other types of aggressive lymphoma or further subtyping was impossible due to technical problems ( $n = 2$  patients), and 4 patients had T-cell lymphoma. Twenty-five patients randomized to Arm B had their diagnosis confirmed by external review. Fourteen of these patients (56%) had diffuse large B-cell lymphoma, and 4 patients had other types of aggressive lymphoma. T-cell lymphoma was diagnosed in seven patients ( $P = 0.09$ , if compared with Arm A). Further patient characteristics are given in Table 2. There were no significant differences noted between patients randomized to Arm A or Arm B except for the percentage of patients with bulky disease and the involvement of more than one extranodal site.

**TABLE 2**  
Patient Characteristics

	Arm A	Arm B	<i>P</i> value
No.	41	26	
Female gender, %	54	39	0.225
Median age in yrs	45.0	49.5	0.648
LDH > ULN, %	100	100	–
Ann Arbor Stage III/IV disease, %	73	85	0.273
ECOG performance status 2–4, %	42	23	0.122
IPI of 1, %	20	15	0.471
IPI of 2, %	46	62	
IPI of 3, %	34	23	
B symptoms, %	61	46	0.234
Extranodal disease, %	61	56	0.690
Extranodal sites > 1, %	44	19	0.038
Bulky disease, %	76	50	0.031

LDH: lactate dehydrogenase; ULN: upper limit of normal; ECOG: Eastern Cooperative Oncology Group; IPI: International Prognostic Index.

### Collection and Transplantation of Hematopoietic Stem Cells

In Arm A, only  $1.32 \times 10^6$  CD34-positive cells/kg were collected from 1 patient after Course 1; after Course 2,  $5.71 \times 10^6$  cells/kg were harvested and the patient received all treatment. Thirty-eight patients received a median of  $8.4 \times 10^6$  CD34-positive cells/kg after Course 2 (range,  $1.3$ – $69.2 \times 10^6$  CD34-positive cells/kg); 35 patients received  $3.5 \times 10^6$  CD34-positive cells/kg (range,  $1.6$ – $21.9 \times 10^6$  CD34-positive cells/kg) and  $3.4 \times 10^6$  CD34-positive cells/kg (range,  $0.6$ – $22.0 \times 10^6$  CD34-positive cells/kg) after Courses 3 and 4, respectively. Mobilization failures were not observed, although the number of PBSC infused became lower (Fig. 2) and the number of leukaphereses needed to collect  $\geq 2 \times 10^6$  CD34-positive cells/kg increased with time. In Arm B, we failed to collect  $> 2 \times 10^6$  CD34-positive cells after Courses 4 and 5 in 1 patient each and could not proceed as per protocol. The other patients were transplanted with a median of  $3.7 \times 10^6$  CD34-positive cells/kg (range,  $1.8$ – $11.5 \times 10^6$  CD34-positive cells/kg),  $3.4 \times 10^6$  CD34-positive cells/kg (range,  $1.4$ – $16.0 \times 10^6$  CD34-positive cells/kg), and  $3.5 \times 10^6$  CD34-positive cells/kg (range,  $2.0$ – $16.0 \times 10^6$  CD34-positive cells/kg) after the 4th, 5th, and 6th course of therapy, respectively. Therefore, harvesting PBSC late (after Courses 3 and 4) resulted in the collection of significantly fewer stem cells (Fig. 2) compared with harvesting after Courses 1 and 2, and 2 patients (8%) failed to mobilize adequate numbers of PBSC. All patients who actually underwent transplantation engrafted.

**FIGURE 2.** Peripheral blood stem cells (CD34-positive cells) reinfused after treatment Courses 2–4 (in Arm A) or treatment Courses 4–6 (Arm B) of the dose-escalated cyclophosphamide, doxorubicin, vincristine, prednisone plus etoposide regimen (megaCHOEP). Boxplots indicate the median, the 25% and 75% percentiles, and the ranges of the CD34-positive cells infused.

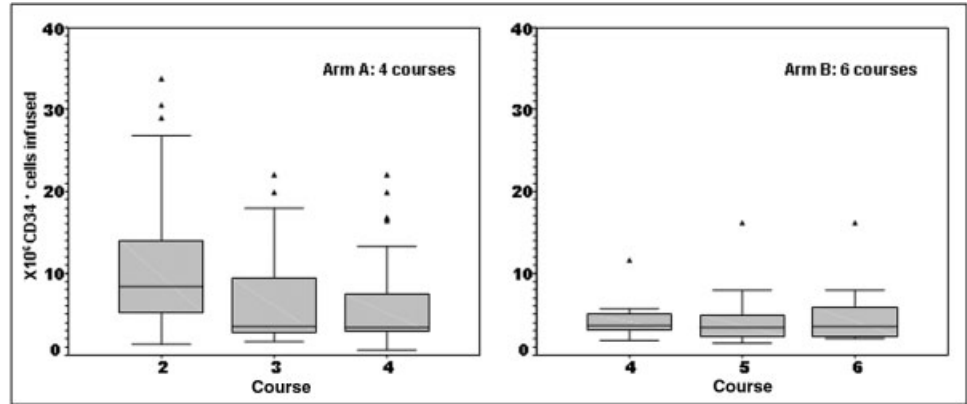

### Hematologic Recovery, Time Intervals between Treatment Courses, and Duration of Treatment

In Arm A, a leukocyte count  $> 1/nL$  was reached after a median of 13 days, 15 days, 15 days, and 16 days; and a platelet count  $> 80/nL$  was achieved at a median of 15 days, 16 days, 19 days, and 21 days after the 1st, 2nd, 3rd, and 4th treatment courses, respectively. The median time intervals between Courses 1 and 2, Courses 2 and 3, and Courses 3 and 4 were 22 days, 28 days, and 30 days, respectively (Fig. 3). This added up to a median treatment duration of 99 days, which was 15 days (18%) longer than planned. In Arm B, a leukocyte count  $> 1/nL$  was reached after a median of 13 days, 13 days, 14 days, 16 days, 16 days, and 16 days; and a platelet count  $> 80/nL$  was reached after a median of 15 days, 15 days, 16 days, 20 days, 21 days, and 28 days after treatment Courses 1–6, respectively (Fig. 3). The median time intervals between treatment courses were 22 days, 22 days, 24 days, 27 days, and 29 days, respectively, for a median treatment duration of 142 days, which was 16 days (13%) longer than planned.

### Nonhematologic Toxicities

The major toxicities observed in both treatment arms were mucositis, gastrointestinal symptoms, and infections. Grade 4 toxicity (infectious) were reported to have occurred in 1.9% of all treatment courses within Arm A; no Grade 4 toxicity was observed in Arm B. Grade 3 toxicities were reported to have occurred in 10.3% and 2.9% (stomatitis), 3.2% and 0% (gastrointestinal), and 5.8% and 7.9% (infections) of all treatment courses in Arms A and B, respectively. Significantly more toxic events were observed in those patients treated on Arm A with regard to stomatitis ( $P < 0.001$ ) and liver toxicity ( $P = 0.032$ ); CNS toxicity was found to be of a higher grade ( $P = 0.007$ ).

### Doses and Dose Intensities Received

The total doses of drugs and the respective dose intensities are listed in Table 1. There were only small differences noted between the planned doses and the doses actually received for any drug administered. The received dose intensities varied between 76.2–88.0%, with no significant differences noted between treat-

**FIGURE 3.** Boxplots indicating the leukocyte (“white blood cell” [WBC]) (open bars) and platelet (Pit) (striped bars) recovery after individual treatment courses as well as the time to next treatment (solid bars). Comparison is between treatment Arms A and B.

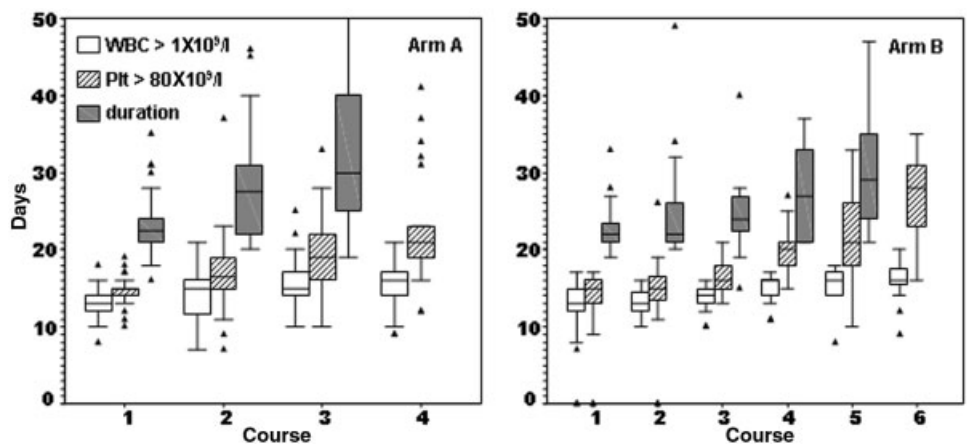

ment arms. The dose intensities for cyclophosphamide and etoposide were significantly higher in Arm A compared with Arm B. The most striking differences were noted during the first three treatment courses. Early total doses of cyclophosphamide and etoposide were 2.8-fold higher and 2.0-fold higher, respectively, in Arm A compared with Arm B. The early dose intensity of cyclophosphamide in Arm A was 2.42-fold and the early dose intensity of etoposide was 1.73-fold higher than in Arm B. Patients randomized to Arm A received 70.2% of all cyclophosphamide doses and 71.2% of all etoposide doses with treatment Courses 1–3 whereas patients in Arm B received only 25.2% of all cyclophosphamide doses and 37.4% of all etoposide doses during the same time period.

### Treatment Outcome

In Arm A of the megaCHOEP regimen, 37 patients (90.2%) received all planned therapy. Four patients (9.8%) withdrew from treatment prematurely after Courses 1, 2 ( $n = 2$  patients), or 3 because of toxic events (pneumonia, adult respiratory distress syndrome, and ileus) or protocol violation. Twenty-seven patients (65.9%) achieved a CR, 4 patients (9.8%) achieved a PR, and 9 patients (22.0%) progressed 2.7–5.6 months after the initiation of therapy. In Arm B, 18 patients (69.2%) completed all therapy. Eight patients stopped treatment after Courses 1, 3, 4 (two patients), or 5 (four patients) because of progressive disease (four patients), toxicity (two patients), or failure to mobilize adequate numbers of PBSC (two patients). Thirteen patients (50%) achieved a CR, 4 patients (15.4%) achieved a PR, and 8 patients (30.8%) progressed 1.4–6.8 months after the initiation of treatment. The overall survival rate of patients with disease progression or recurrence at 2 years was 47.5% (95% CI, 31.8–63.1%) in Arm A and 74.0% (95% CI, 56.8–91.2%) in Arm B of the study ( $P = 0.036$ ) (Fig. 4). With a median follow-up of 29 months and 38 months, respectively, for patients in Arm A and Arm B, 13 of 41 patients (31.7%) in Arm A and 16 of 26 patients (61.5%) in Arm B had died. The cause of death was lymphoma in all but three cases. Two patients randomized to Arm A and Arm B, respectively, died of treatment-related toxicity. A third patient died 31 months after diagnosis with a myelodysplastic syndrome; he also had previously developed disease recurrence with immunoblastic lymphoma and received additional therapy. At 2 years, the overall survival rate in Arm A (70.0%; 95% CI, 54.9–85.0%) was significantly better ( $P = 0.037$ ) than that in Arm B (46.2%; 95% CI, 27.0–65.3%) (Fig. 5).

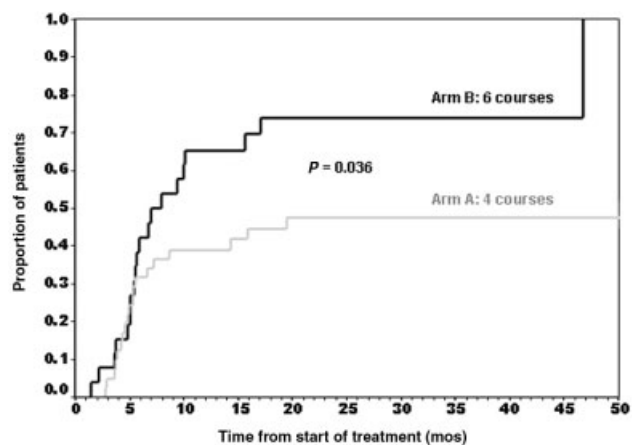

**FIGURE 4.** Time to disease progression or disease recurrence for patients treated on Arm A or Arm B of the dose-escalated cyclophosphamide, doxorubicin, vincristine, prednisone plus etoposide regimen (megaCHOEP).

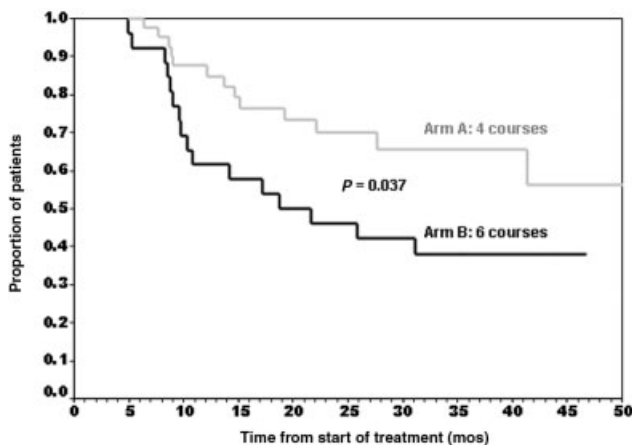

**FIGURE 5.** Overall survival of patients treated on Arm A or Arm B of the dose-escalated cyclophosphamide, doxorubicin, vincristine, prednisone plus etoposide regimen (megaCHOEP).

### Prognostic Factors

The results of a multivariate analysis including risk factors of the age-adjusted IPI are presented in Table 3. In addition to poor ECOG performance status, which increased the risk for treatment failure 2.4-fold ( $P = 0.014$ ), only treatment with 6 rather than 4 courses of the megaCHOEP regimen was found to significantly increase the risk of treatment failure (relative risk [RR] of 2.6;  $P = 0.007$ ) or death (RR of 2.4;  $P = 0.028$ ). When we adjusted the model for the age-adjusted IPI, the number of treatment courses remained highly significant for time to treatment failure (RR of 2.4; 95% CI, 1.2–4.7 [ $P = 0.009$ ]) and overall survival (RR of 2.2; 95% CI, 1.0–4.7 [ $P = 0.044$ ]).

**TABLE 3**  
**Prognostic Factors for FFTF in Patients Treated with MegaCHOEP**

Factor	RR	95% CI	P value
4 cycles vs. 6 cycles	2.6	(1.3–5.1)	0.007
LDH ≤ twice the ULN vs. > twice the ULN	0.9	(0.5–1.9)	0.864
Ann Arbor Stage I/II vs. Stage III/IV disease	2.6	(0.9–7.5)	0.082
ECOG performance status 0/1 vs. > 1	2.4	(1.2–4.9)	0.014

FFTF: freedom from treatment failure; MegaCHOEP: dose-escalated cyclophosphamide, doxorubicin, vincristine, and prednisone plus etoposide; RR: relative risk; 95% CI: 95% confidence interval; ULN: upper limit of normal; ECOG: Eastern Cooperative Oncology Group.

## DISCUSSION

Because the results of standard CHOP or equivalent regimens in younger patients with poor prognosis aggressive lymphoma are far from satisfactory,<sup>2</sup> and the majority of randomized studies exploring the efficacy of HDT/ASCT were unable to demonstrate significant improvements over conventional treatment,<sup>3,5–8</sup> we designed an alternative concept characterized by the early and repeated administration of a combination of dose-escalated drugs frequently used for the first-line therapy of aggressive lymphoma. Because in previous trials up to 40% of patients randomized to HDT did not receive it (mostly because of early disease progression), our first goal was to increase the doses and dose intensity from the initiation of therapy, hoping that more patients would be able to benefit from HDT. Indeed, in Arm A of the megaCHOEP regimen, greater than 90% of patients were able to receive all treatment. In contrast, only 69% of patients in Arm B completed all therapy and, most strikingly, the vast majority of patients treated on Arm B developed disease progression while receiving therapy or disease recurrence shortly thereafter. The percentage of patients with disease progression or early recurrence was significantly lower in Arm A. In both study arms, no cases of disease recurrence occurred beyond 20 months.

Second, with the repeated administration of escalated doses of cyclophosphamide and etoposide, we intended to further increase the total dose and dose intensity compared with other high-dose regimens used before ASCT. The total doses of cyclophosphamide and etoposide given with the megaCHOEP regimen amount to 19,500 mg/m<sup>2</sup> or 19,800 mg/m<sup>2</sup> (Arms A/B) and 5040 mg/m<sup>2</sup> or 5200 mg/m<sup>2</sup> (Arms A/B), respectively, compared with 5800–6000 mg/m<sup>2</sup> of cyclophosphamide and 800–2000 mg/m<sup>2</sup> of etoposide used with the combination of carmustine, etoposide, cytarabine, cyclophosphamide, and mesna (BEAC); carmustine, etoposide, cytarabine, and melphalan (BEAM); or cyclophosphamide, carmustine, and eto-

poside (CBV).<sup>4,8,13</sup> Of course, it remains difficult to compare the doses and antilymphoma effects of the megaCHOEP regimen with those of other regimens because neither the doses of the drugs administered with megaCHOEP can be compared directly with those of the carmustine or cytarabine used in the BEAM or BEAC regimens, nor is it possible to judge what the contribution of individual drugs to the overall antitumor effect may be. Compared with conventional CHOEP-21, which we used in recent studies for young, low-risk patients<sup>14</sup> and elderly patients,<sup>15</sup> the doses of cyclophosphamide and etoposide administered with the megaCHOEP therapy Arm A were 4.3-fold (cyclophosphamide) and 2.8-fold higher, respectively, and the respective dose intensities were 6.5-fold and 4.2-fold higher, respectively. Such substantial increases in dose and dose intensity were possible only with repeated stem cell support. We confirmed that collection of numbers of stem cells sufficient to allow for three sequential transplants is possible in patients undergoing aggressive antilymphoma therapy.<sup>16</sup> However, late collections after the third course of therapy were compromised by lower yields of CD34-positive cells and a low (8%), albeit clinically significant, number of mobilization failures.

We randomized patients between two strategies to increase the doses and dose intensity because we wanted to determine whether it would be preferable to administer high doses and dose intensity very early but also for a relatively short period of time (Arm A) or if a sequential strategy would be superior starting with a period of moderate dose escalation for the first three treatment courses followed by three more courses of escalated megaCHOEP necessitating the transplantation of hematopoietic stem cells. The answer to our question was surprisingly clear. The six-course variant of megaCHOEP led to disease progression or early recurrence in significantly more patients than the four-course program; overall survival was also found to differ significantly in favor of the latter group. We consider this proof that in poor prognosis patients with aggressive lymphoma, in whom the fraction of dividing tumor cells can be as high as 90%,<sup>17</sup> it is not only the total dose or dose intensity but also the early administration of the highest possible doses of cytotoxic agents that make the difference. Early doses and dose intensities for cyclophosphamide and etoposide as given with Arm B were only 33–50% of that given with Arm A (Table 1). The importance of the early administration of high doses and dose intensities is highlighted also by the results of the French Groupe d'Etude des Lymphomes de l'Adulte (GELA) LNH93-3 trial, which to our knowledge is the only study to date to report inferior results of HDT compared with con-



ventional therapy.<sup>6</sup> Gisselbrecht et al. explained that their findings resulted from an inadequate dose intensity for the experimental treatment arm during the first 2 months of the trial and we agree.<sup>6</sup> In a recent meta-analysis, Strehl et al. came to similar conclusions when they stated that early treatment delays may be detrimental and an advantage for HDT over conventional chemotherapy can be expected only if the dropout rate for patients on the HDT arm is less than 25%.<sup>18</sup> In keeping with these postulates, to our knowledge the only study to date that randomized high-intermediate and high-risk patients at the time of diagnosis and demonstrated a benefit for HDT was the one by Gianni et al.,<sup>19</sup> which used a rapid sequence of single drugs administered at very high doses early in the study.

In the recently published studies comparing CHO(E)P given at 3-week versus 2-week intervals, we demonstrated that shortening of the time intervals between treatment courses as another means to increase dose intensity or dose density was feasible and significantly improved outcome in the elderly.<sup>15</sup> However, shortening of the time intervals between courses of megaCHOEP to less than 21 days was not possible because of persistent nonhematologic toxicity and the reduced performance status of patients early after treatment courses.

The role of rituximab, which has been reported to improve the outcome of younger patients with low-risk, aggressive NHL<sup>20</sup> as well as elderly patients,<sup>21</sup> must also be considered in young, high-risk patients. Although the DSHNHL currently is performing a prospective, randomized study comparing megaCHOEP plus rituximab with CHOEP-14 plus rituximab, no data are available at the present time to demonstrate a significant role for rituximab in young, high-risk patients treated with conventional chemotherapy or HDT. Therefore, determining the optimal administration of cytotoxic drugs remains important in the near future. In the current study, we demonstrated that very high doses and dose intensities can be administered safely to young, high-risk patients and optimal efficacy can be achieved only if the dose intensity is escalated early during treatment and remains high throughout therapy.

## REFERENCES

- [no authors listed]. A predictive model for aggressive non-Hodgkin's lymphoma. The International Non-Hodgkin's Lymphoma Prognostic Factors Project. *N Engl J Med*. 1993; 329:987-994.
- Fisher RI, Gaynor ER, Dahlborg S, et al. Comparison of a standard regimen (CHOP) with three intensive chemotherapy regimens for advanced non-Hodgkin's lymphoma. *N Engl J Med*. 1993;328:1002-1006.
- Santini G, Salvagno L, Leoni P, et al. VACOP-B versus VACOP-B plus autologous bone marrow transplantation for advanced diffuse non-Hodgkin's lymphoma: results of a prospective randomized trial by the non-Hodgkin's Lymphoma Cooperative Study Group. *J Clin Oncol*. 1998;16:2796-2802.
- Haïoun C, Lepage E, Gisselbrecht C, et al. Survival benefit of high-dose therapy in poor-risk aggressive non-Hodgkin's lymphoma: final analysis of the prospective LNH87-2 protocol—a groupe d'Etude des lymphomes de l'Adulte study. *J Clin Oncol*. 2000;18:3025-3030.
- Kluin-Nelemans HC, Zagonel V, Anastasopoulou A, et al. Standard chemotherapy with or without high-dose chemotherapy for aggressive non-Hodgkin's lymphoma: randomized Phase III EORTC study. *J Natl Cancer Inst*. 2001;93:22-30.
- Gisselbrecht C, Lepage E, Molina T, et al.; Groupe d'Etude des Lymphomes de l'Adulte. Shortened first-line high-dose chemotherapy for patients with poor-prognosis aggressive lymphoma. *J Clin Oncol*. 2002;20:2472-2479.
- Kaiser U, Uebelacker I, Abel U, et al. Randomized study to evaluate the use of high-dose therapy as part of primary treatment for "aggressive" lymphoma. *J Clin Oncol*. 2002; 20:4413-4419.
- Martelli M, Gherlinzoni F, De Renzo A, et al. Early autologous stem-cell transplantation versus conventional chemotherapy as front-line therapy in high-risk, aggressive non-Hodgkin's lymphoma: an Italian multicenter randomized trial. *J Clin Oncol*. 2003;21:1255-1262.
- Milpied N, Deconinck E, Gaillard F, et al.; Groupe Ouest-Est des Leucémies et des Autres Maladies du Sang. Initial treatment of aggressive lymphoma with high-dose chemotherapy and autologous stem cell support. *N Engl J Med*. 2004; 350:1287-1295.
- Bearman SI, Appelbaum FR, Buckner CD, et al. Regimen-related toxicity in patients undergoing bone marrow transplantation. *J Clin Oncol*. 1988;6:1562-1568.
- Hryniuk WM, Goodyear M. The calculation of received dose intensity. *J Clin Oncol*. 1990;8:1935-1937.
- Pocock SJ. Clinical trials. Chichester, UK: John Wiley & Sons, 1983.
- Wheeler C, Antin JH, Churchill WH, et al. Cyclophosphamide, carmustine, and etoposide with autologous bone marrow transplantation in refractory Hodgkin's disease and non-Hodgkin's lymphoma: a dose-finding study. *J Clin Oncol*. 1990;8:648-656.
- Pfreundschuh M, Trumper L, Kloess M, et al.; German High-Grade Non-Hodgkin's Lymphoma Study Group. Two-weekly or 3-weekly CHOP chemotherapy with or without etoposide for the treatment of young patients with good-prognosis (normal LDH) aggressive lymphomas: results of the NHL-B1 trial of the DSHNHL. *Blood*. 2004;104:626-633.
- Pfreundschuh M, Trumper L, Kloess M, et al.; German High-Grade Non-Hodgkin's Lymphoma Study Group. Two-weekly or 3-weekly CHOP chemotherapy with or without etoposide for the treatment of elderly patients with aggressive lymphomas: results of the NHL-B2 trial of the DSHNHL. *Blood*. 2004;104:634-641.
- Stoppa AM, Bouabdallah R, Chabannon C, et al. Intensive sequential chemotherapy with repeated blood stem cell support for untreated poor prognosis non-Hodgkin's lymphoma. *J Clin Oncol*. 1997;15:1722-1729.

17. Miller TP, Grogan TM, Dahlberg S, et al. Prognostic significance of the Ki-67-associated proliferation antigen in aggressive non-Hodgkin's lymphoma: a prospective Southwest Oncology Group Trial. *Blood*. 1994;83:1460–1466.
18. Strehl J, Mey U, Glasmacher A, et al. High-dose chemotherapy followed by autologous stem cell transplantation as first-line therapy in aggressive non-Hodgkin's lymphoma: a meta-analysis. *Haematologica*. 2003;88:1304–1315.
19. Gianni AM, Bregni M, Siena S, et al. High-dose chemotherapy and autologous bone marrow transplantation compared with MACOP-B in aggressive B-cell lymphoma. *N Engl J Med*. 1997;336:1290–1297.
20. Pfreundschuh M, Truemper L, Gill D, et al. First analysis of the completed Mabthera International (Mint) trial in young patients with low-risk diffuse large b-cell lymphoma (DLBCL): addition of rituximab to a CHOP-like regimen significantly improves outcome of all patients with the identification of a very favorable subgroup with IPI = 0 and no bulky disease [abstract 157]. *Blood*. 2004; 104:48a.
21. Coiffier B, Lepage E, Briere J, et al. CHOP chemotherapy plus rituximab compared with CHOP alone in elderly patients with diffuse large-B-cell lymphoma. *N Engl J Med*. 2002;346:235–242.